

Voluntary Guidelines for

FLOOR-READY MERCHANDISE

8.0 Anti-Theft Tag Placement

2nd Edition

Latest Revision: September 15, 2006



Copyright © 1994 - 2006

Voluntary Interindustry Commerce Solutions Association

All rights reserved.

Table of Contents

Section	Title	Page
	Table of Contents	3
	Revision Summary	4
8.0	Anti-Theft Tag Placement	5
8.1	Introduction	5
8.1.1	Overview	5
8.1.2	Benefits	5
8.1.3	Important Considerations	6
8.2	Anti-Theft Tag types	6
8.3	Placement Guidelines	7
8.3.1	Product Categories	7
8.3.2	Placement Guidelines	7
8.3.2.1	Disposable Anti-Theft Tags - Apparel and Accessories	8
8.3.2.2	Disposable Anti-Theft Tags - Other Products	27
8.3.2.3	Removed at Point-of-Sale Anti-Theft Tags	31
8.4	Training Considerations	45
8.5	Trading Partner Discussion Checklist	45

Revision Summary

Date	Section	Page	Revision
15-Sep-06	All	All	2nd Edition published.

8.0 Anti-Theft Tag Placement

8.1 Introduction

8.1.1 Objective

Provide placement guidelines for anti-theft tags on general merchandise and apparel.

8.1.2 Overview

The utilization of anti-theft tags, both Electronic Article Surveillance (EAS) technology and benefit denial, has proven to be an effective and valuable tool for addressing the problem of inventory shrink in the retail environment for more than 25 years.

There are currently two entrenched EAS technologies in North America that are incompatible: Radio Frequency (RF) and acousto-magnetic (AM). A third system, electro-magnetic (EM) has significant market share in Europe. In addition to EAS technology, the utilization of benefit denial anti-theft tags, such as tags with permanent ink or locking devices, is commonplace in the retail environment.

Anti-theft tags are commonly applied to general merchandise and apparel in three methods:

- ◆ by the retailer at the retail or distribution point,
- ◆ by the manufacturer at the factory, or
- ◆ by the manufacturer or supplier at the distribution point.

The purpose of these guidelines is not to address which type of anti-theft tag or technology used or which trading partner should apply the anti-theft tag. The trading partners should make these decisions.

These guidelines address the placement of all types of anti-theft tags on general merchandise and apparel. The anti-theft tag placement guidelines support the VICS Floor Ready Merchandise objectives: Reduce the time to move general merchandise and apparel to the retail, selling floor and to provide the best overall value for the consumer.

8.1.3 Important Considerations

- ◆ Anti-theft tag placement should be consistent with the GS1 US® *Guidelines for Symbol Placement* documents: Apparel Guidelines: [Format and Symbol Placement](#), [Tabletop and Giftware Marking Guidelines](#) and excerpts of the [General GS1 Specifications, Chapter 6](#).
- ◆ Placement of anti-theft tags must not obscure the bar code symbol, retail price, or product information marking on the product.
- ◆ Product packaging.
- ◆ Merchandise category and product type.
- ◆ Merchandising and/or presentation method.

- ◆ Consumer comfort and reaction.
- ◆ Activation, deactivation, or removal as applicable.
- ◆ Administration of the application process dependent on the type of anti-theft tag used and where the application takes place. For example, retail, distribution, or manufacturing.

8.1.4 Benefits

Consistent anti-theft tag placement:

- ◆ Facilitates reliable activation, deactivation, or removal as applicable, streamlining point-of-sale activity.
- ◆ Reduces false alarms caused by failure to deactivate or remove as applicable.
- ◆ Reduces potential damage to merchandise caused by improper application or removal.
- ◆ Facilitates execution of merchandising and/or presentation objectives.
- ◆ Improves consumer shopping experience by considering tag location during trying on apparel or accessories.
- ◆ Facilitates tagging compliance inspections.

8.2 Anti-Theft Tag Types

These guidelines address the placement of all types of anti-theft tags, currently available at the time of publication, on general merchandise and apparel. New tag types that may require different placement requirements will be addressed as a revision to this document.

- ◆ Disposable: Deactivated at point of sale; generally removed and discarded by the consumer. May also be removed and discarded at point-of-sale Includes the following:
 - ◆ Fabric - pouch with EAS device enclosed and sewn onto garment
 - ◆ Paper - EAS device integrated into paper hang tag, pocket flasher, swing ticket
 - ◆ Plastic - EAS device imbedded or encased in plastic; for example, plastic hanger, integrated seal, disposable hard tag, or disposable hard tag and lanyard
- ◆ Removed at Point-of-Sale: Generally applied by the retailer and removed by the retailer at point of sale. Includes the following:
 - ◆ Hard tags - EAS device encased in plastic housing, with tack or clamp application
 - ◆ Benefit denial - Anti-theft devices with vials of permanent ink that, if defeated, render the merchandise worthless; or locking devices that must be removed at point of sale.

8.3 Placement Guidelines

8.3.1 Product Categories

- ◆ Footwear
- ◆ Apparel: Bottoms, tops, dresses, suits, sport coats, outerwear
- ◆ Intimate Apparel: Bras, underwear (boxers, panties, control garments), camisoles/teddies, sleepwear/robes, slippers, swimwear/body wear/dancewear (1 and 2 piece)
- ◆ Accessories: Jewelry, watches, handbags, small leather goods, belts/suspenders, millinery, scarves/shawls, gloves/mittens, eyewear, ties/neckwear
- ◆ Packaged Apparel: Banded; boxed, flap; boxed, lid; carded; flat packed; plastic packaged; and shrink wrapped/plastic
- ◆ Other Products: Cosmetics, housewares, electrics, tabletop, gifts, frames, stationery, soft home (towels, rugs, bedding, table linens)

8.3.2 Placement Guidelines

Placement guidelines follow for two categories of anti-theft tags: Disposable and removed at point-of-sale. The most important consideration in the placement of disposable anti-theft tags is insuring successful activation or deactivation at point-of-sale. Activation or deactivation is successful within a **3-inch radius** of the anti-theft tag. There are several important considerations in the placement guidelines for removed at point-of-sale anti-theft tags:

- ◆ Consumer comfort in trying on apparel or accessories such as eyewear or hats
- ◆ The fabrication of apparel. Delicate fabrics that are easily damaged or fabrications that stretch may require special consideration
- ◆ Visibility of the tag to facilitate locating for removal at point-of-sale
- ◆ The merchandise presentation requirements. Placement of removed at point-of-sale anti-theft tags on folded apparel are different than for hanging apparel

8.3.2.1 Disposable Anti-Theft Tags - Apparel and Accessories

The following placement guidelines apply to disposable anti-theft tags (fabric, paper, and plastic) that are deactivated at point-of-sale and generally removed by the consumer. The preferred placement location for disposable anti-theft tags is within a **3-inch radius** of the bar code placement. This placement ensures successful bar code scanning and, at the same time, successful deactivation of the anti-theft tag. Placement within a 3-inch radius of the bar code may not be convenient or conducive for fabric (sewn-on) anti-theft tags. An alternate placement location for these anti-theft tags is within a 3-inch radius of the sewn-in care or content label(s). The source of the bar code placement presented here is the GS1 US Apparel Guidelines: Format and Symbol Placement, Issue 3 and Tabletop and Giftware Symbol Placement Guideline, Issue 1. (Note: Graphics of products shown here are not actual size. The anti-theft tag placement guidelines depicted are representative of the location relative to the bar code.)

Accessories

Backpacks



Belts

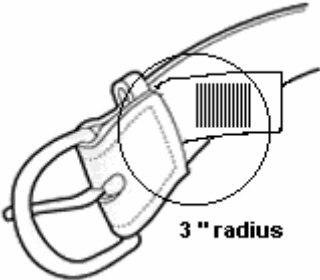

Belts Alternate Placement

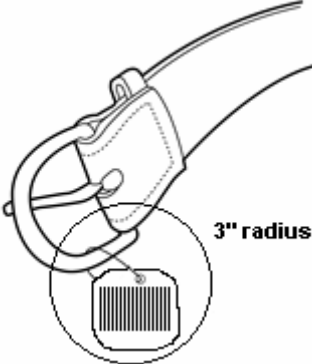

Cummerbunds



Suspenders

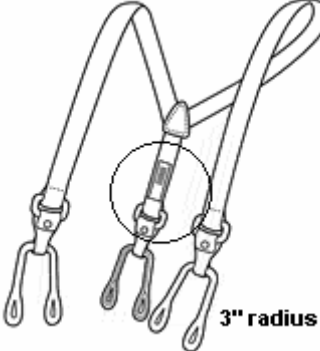

Ties



Accessories

Boxed Jewelry

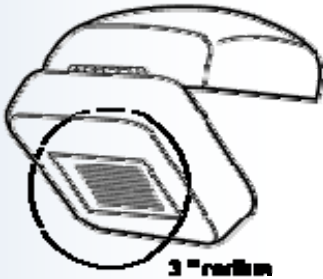

Loose Jewelry



Carded Jewelry

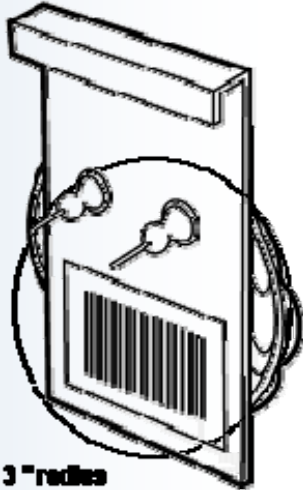

Gloves

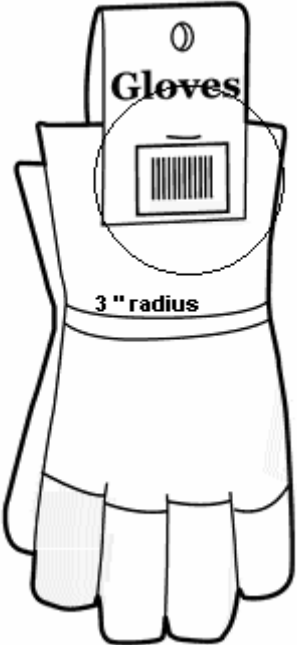
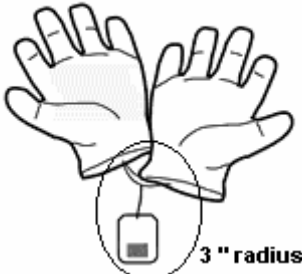

Mittens

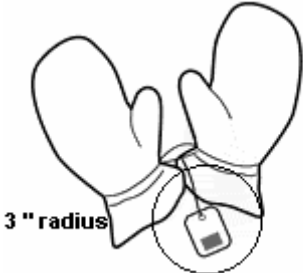

Accessories

Hats

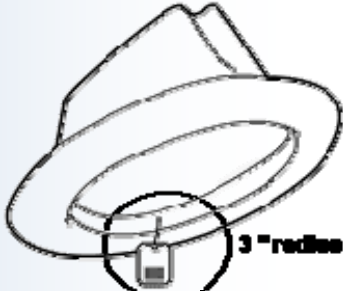

Handbags, Hinged

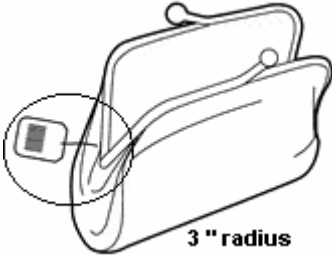

Hats, Knit

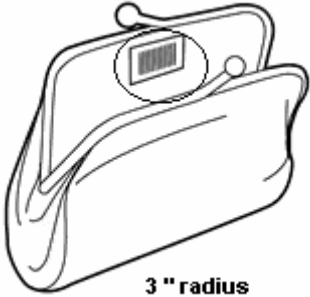
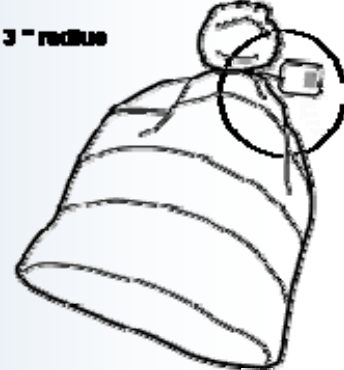

Handbags, Purses

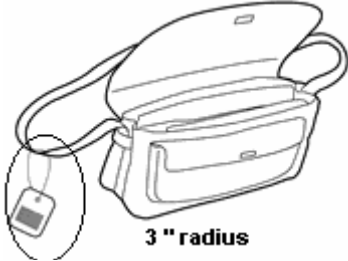

Scarves

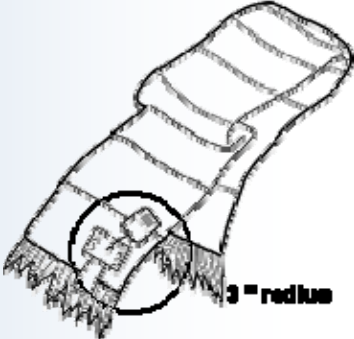
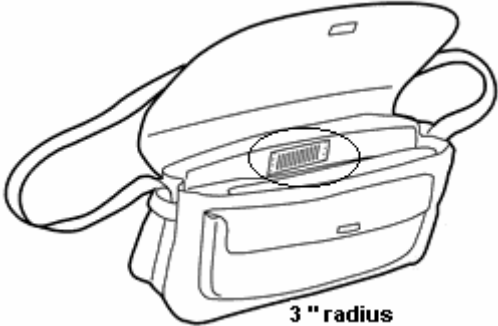

Accessories

Eyewear



Key Chains

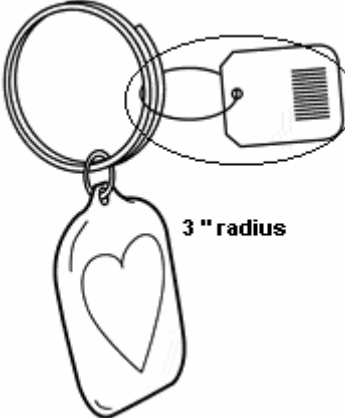

Shawls



Umbrellas



Dickies

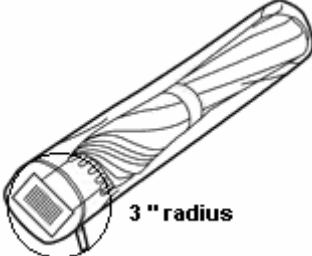

Wallets

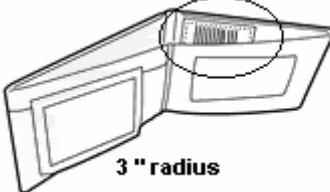

Footwear

Footwear, Open



Footwear, Boxed

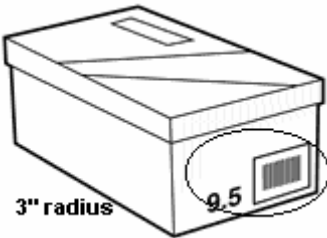

Apparel - Bottoms

Overalls/Shortalls/Rompers

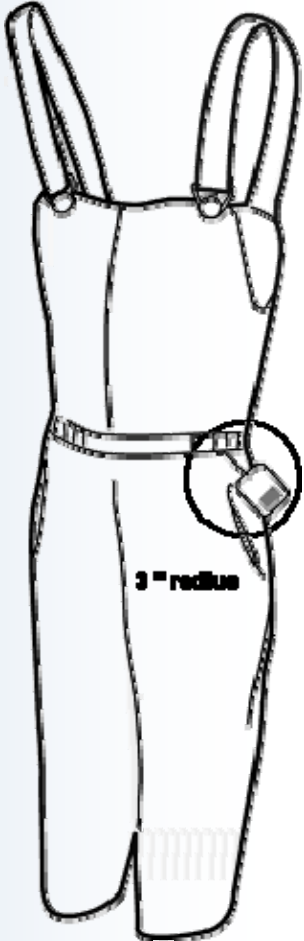

Pants/Slacks/Jeans, Hanging

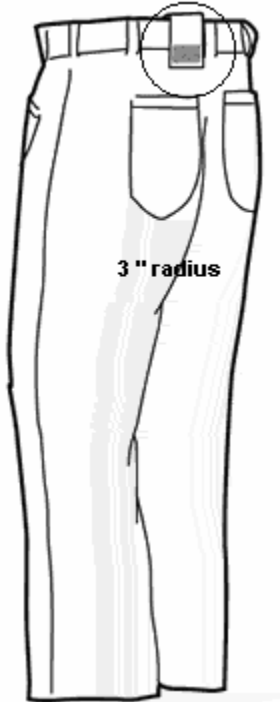

Pants/Slacks/Jeans, Folded

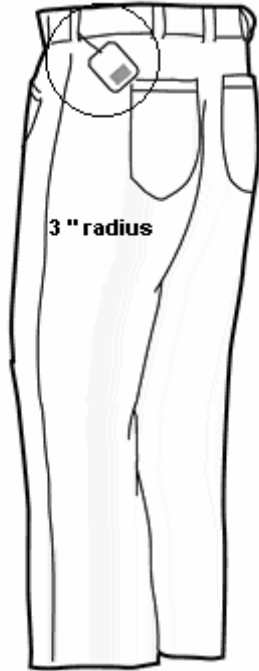
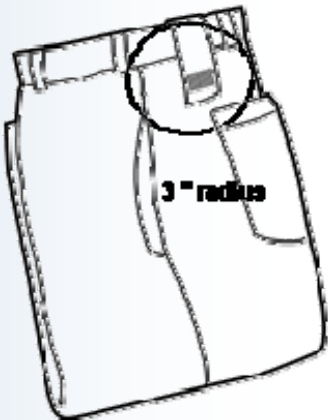

Apparel - Bottoms

Shorts/Trunks

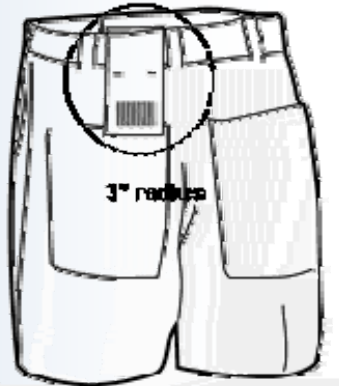

Skirts

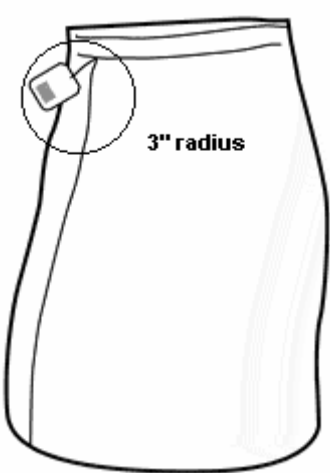

Skirts
Alternate Placement

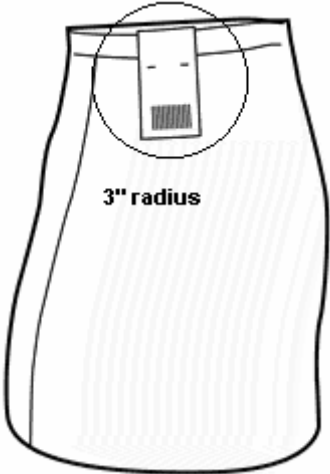

Clothing/Outerwear

Sport Coats/Blazers/Suits



Outerwear (Coats, Jackets)



Sport Coats/Blazers/Suits
Alternate Placement



Outerwear (Parkas, Ponchos)

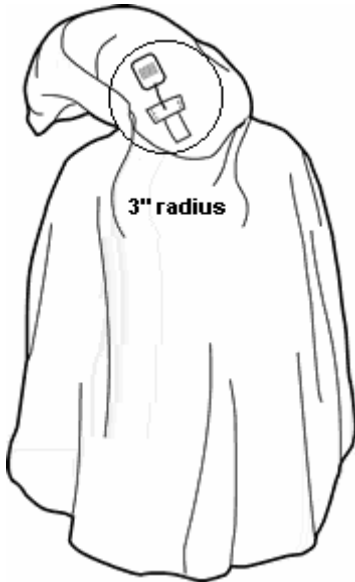

Clothing/Outerwear

Vests



Women's and Girl's Blazers/Suits



Women's and Girl's Blazers/Suits Alternate Placement

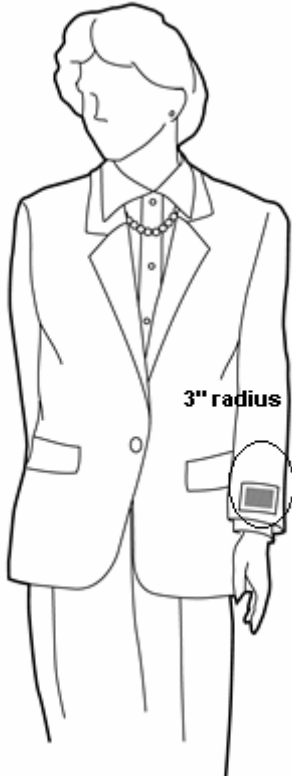

Clothing/Outerwear

Dresses, With Sleeves



Dresses, Sleeveless

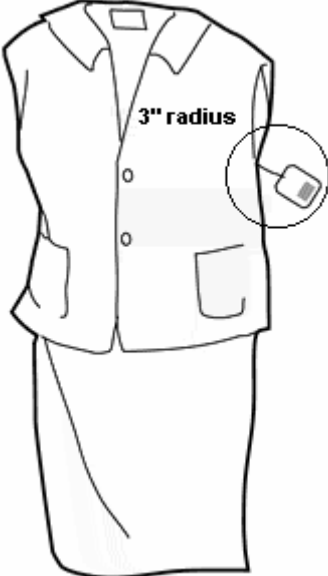

Dresses, With Sleeves
Alternate Placement



Dresses, Sleeveless
Alternate Placement



Tops

Tops, Folded



Tops, Hanging Long Sleeve

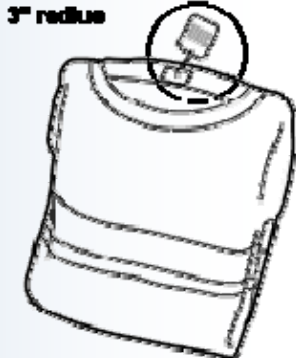

Tops, Hanging Long Sleeve Alternate Placement

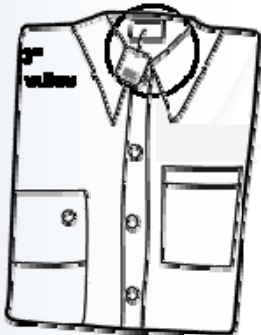

Tops, Folded Alternate Placement

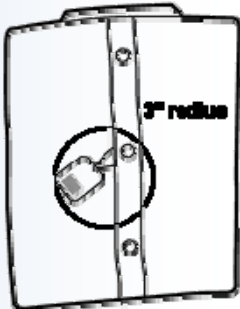

Tops

Tops, Hanging Short Sleeve



Tops, Hanging Sleeveless



Tops, Hanging Short Sleeve Alternate Placement



Tops, Hanging Sleeveless Alternate Placement

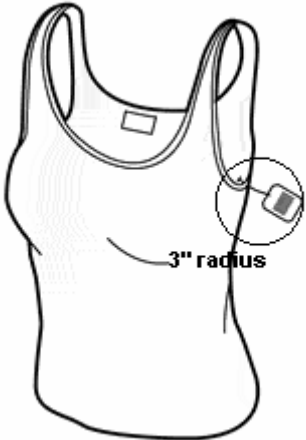

Intimate Apparel/Underwear

Bras



Boxer Shorts

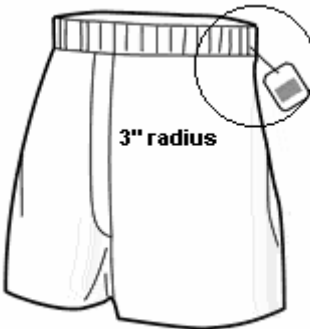

Bras Alternate Placement



Camisoles/Teddies

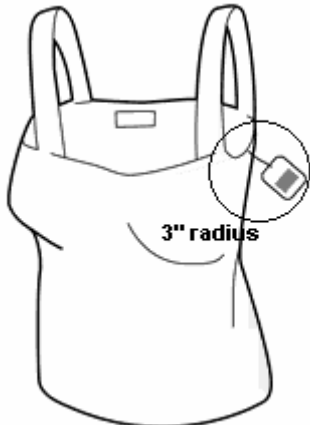

Panties/Control Garments



Camisoles/Teddies Alternate Placement

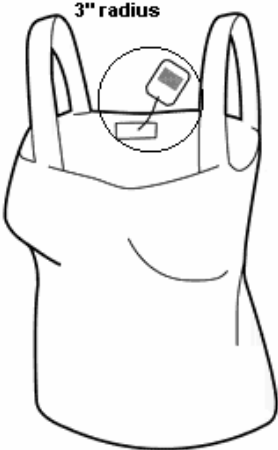

Panties/Control Garments Alternate Placement



Intimate Apparel/Underwear

Sleepwear/Robes

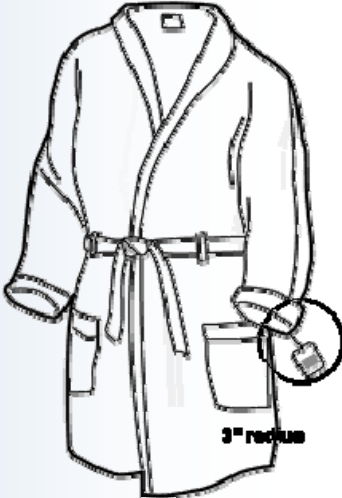

Slips

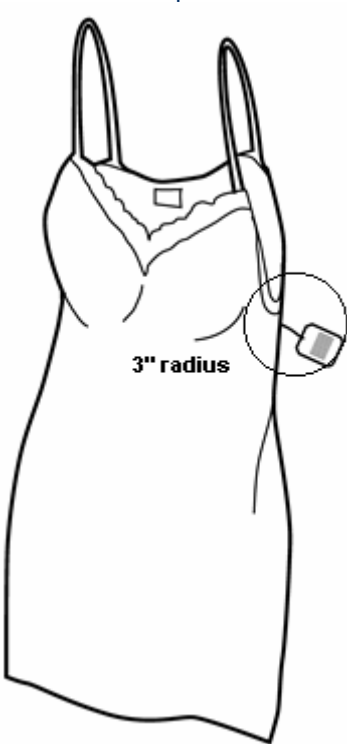

Sleepwear/Robes
Alternate Placement



Slips
Alternate Placement



Intimate Apparel/Underwear

Swimwear/Bodywear/Dancewear, One-Piece

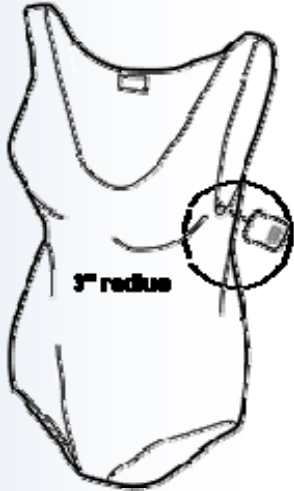

Swimwear, Two-Piece

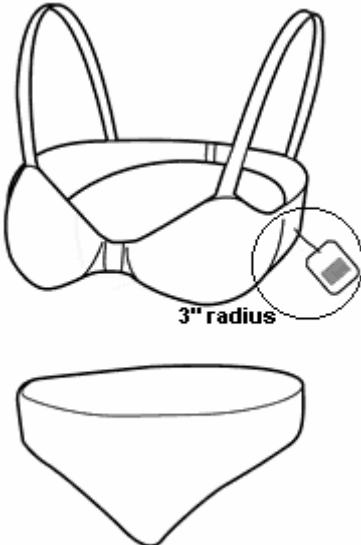

Swimwear/Bodywear/Dancewear, One-Piece Alternate Placement



Swimwear, Two-Piece Alternate Placement

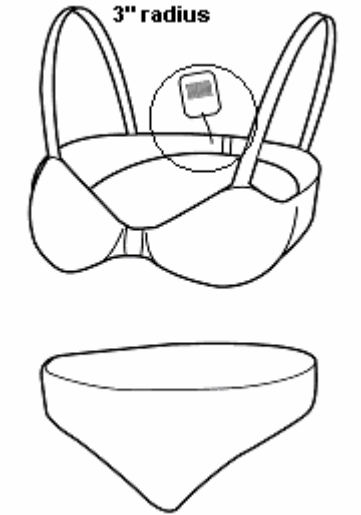

Packaged Apparel

Banded Apparel

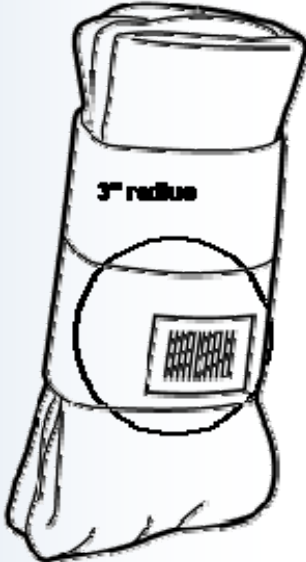

Boxed Apparel, Flap

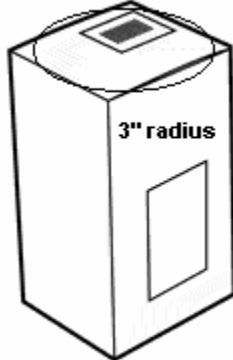
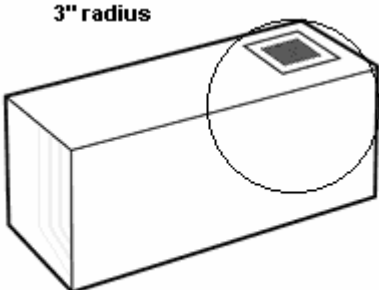

Boxed Apparel, Flap Alternate Placement

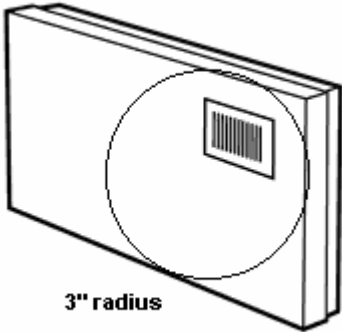

Boxed Apparel, Lid

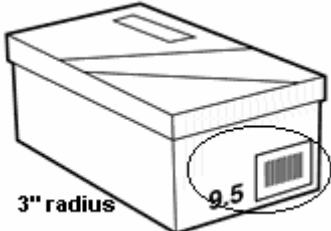

Packaged Apparel

Carded Apparel

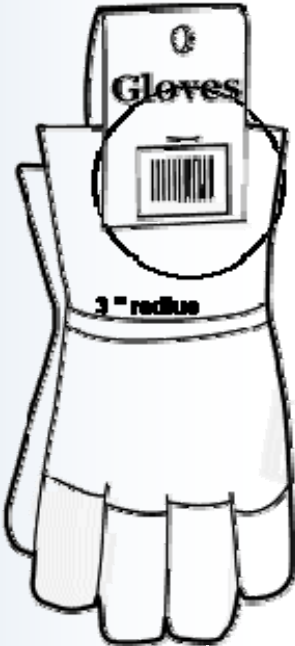

Flat Packed Apparel

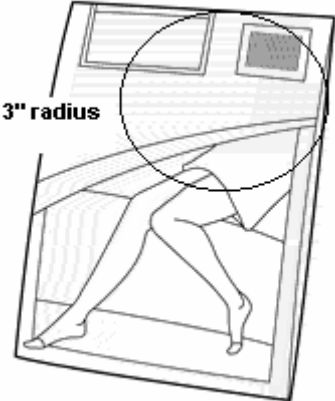

Plastic Packaged Apparel

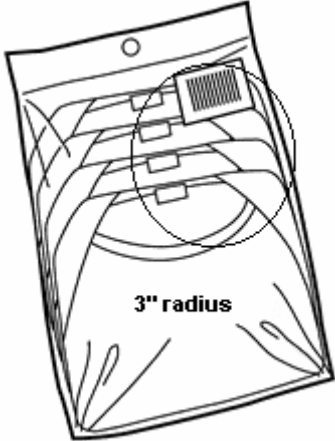

Shirts, Packaged

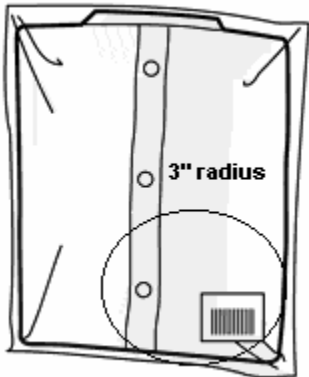

8.3.2.2 Disposable Anti-Theft Tags - Other Products

The products included in this section include cosmetics, housewares, electrics, tabletop, gifts, frames, stationery, and soft home (towels, rugs, bedding, table linens, etc.). If packaged, these products are typically in boxes, plastic or shrink film/vacuum formed packages. In some instances, the products are not packaged at all. In those cases, the bar code is placed directly on the product, on an adhesive sticker or sewn-on fabric or paper label.

The preferred placement location for disposable anti-theft tags is within a **3-inch radius** of the bar code placement. This placement location also applies to fabric (sewn-on) anti-theft tags applied to soft-home products such as bedding or linens. Placement within a 3-inch radius of the bar code ensures both successful bar code scanning and anti-theft tag deactivation.

The GS1 US bar code symbol placement outlined in the various *Guidelines for Symbol Placement* documents are:

- ◆ Plastic Packaged Products

The GS1 Bar Code Symbol and other product identification information on plastic packaged products should normally be located on the front top right-hand corner. However, for some very large, bulky, or unusually shaped product, this may be impractical or inappropriate. See the General GS1 Specifications, Chapter 6, Section 4.9, for large, Heavy, or Bulky Items. (Apparel Guidelines: Format and Symbol Placement, page 24) In some instances, soft home products packaged in zippered plastic bags should have the removable at point-of-sale anti-theft tag placed through the zipper pull to reduce the risk of price switching.

- ◆ Shrink Film/Vacuum Formed Packages

The GS1 bar code symbol on an item packaged in shrink film or that is vacuum-formed should be located on a flat surface and in an area free of creases, wrinkles, or other types of distortion. (Tabletop and Giftware Marking Guideline, page 7)

- ◆ Boxed Products

Before you can begin marking boxes, you must identify the front of the package/container. Refer to the General GS1 Specifications, Chapter 6, Section 3.2, Identifying the Back of the Package, Identifying the Back of the Package, for instructions on how to identify the package front.

- ◆ Preferred Placement: On the lower right quadrant of the back, near the edge, respecting the proper Quiet Zone (light margin) around the bar code symbol.
- ◆ Undesirable Alternative: On the lower right quadrant of the front, near the edge, respecting the proper Quiet Zone (light margin) around the bar code symbol.
- ◆ Bottom Marking: Bottom marking of the trade item with the bar code symbol is acceptable, except for large, heavy, or bulky traded items. However, marking the box on the back (side) is preferred.

(Tabletop and Giftware Marking Guideline, page 10)

Boxed Products
(cosmetics, housewares, electrics, tabletop, gifts, frames, stationery)

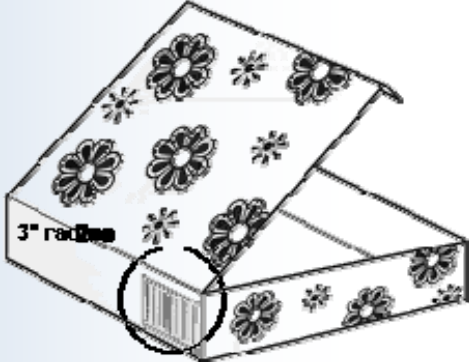
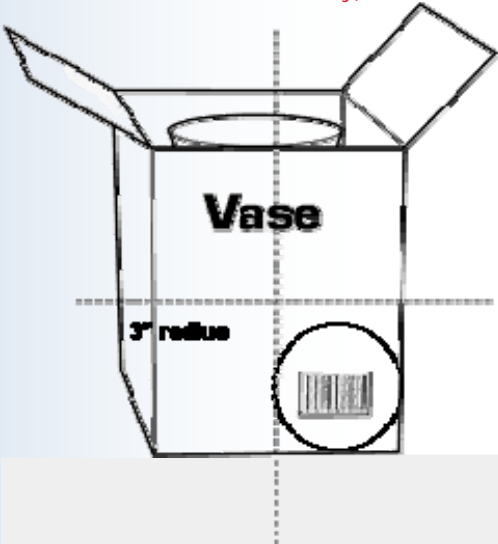

Plastic Packaged Products



Non-Packaged Products, Curved Surfaces

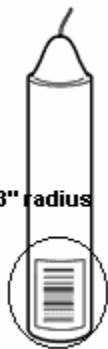
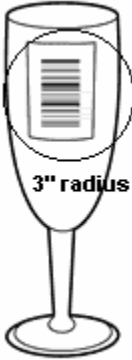

Non-Packaged Products, Bottom Marking

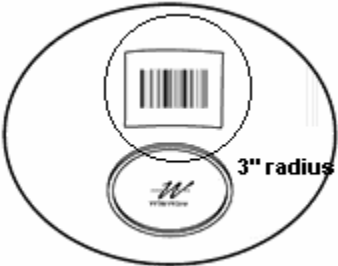
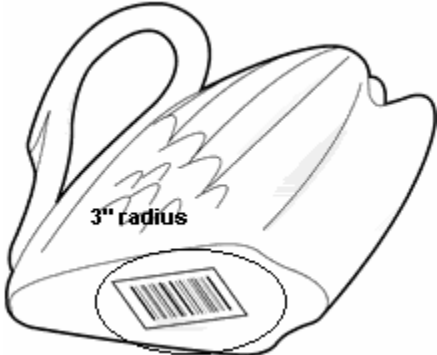
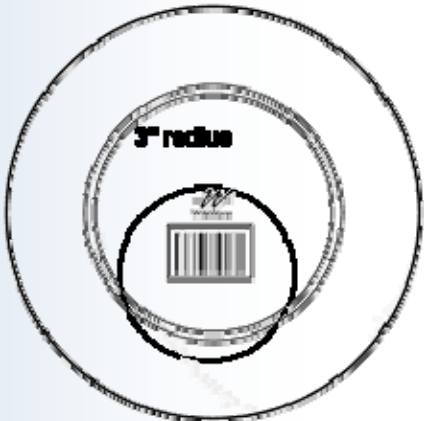

Non-Packaged Products, Bottom Marking

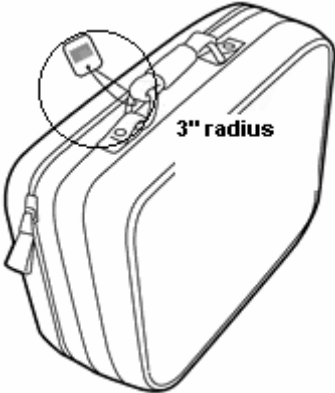
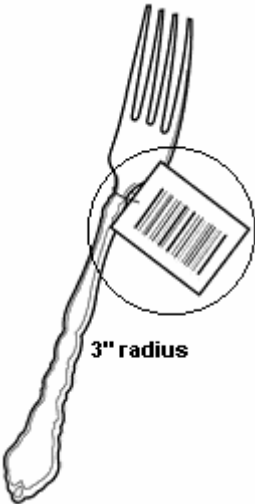

Two Dimensional Products

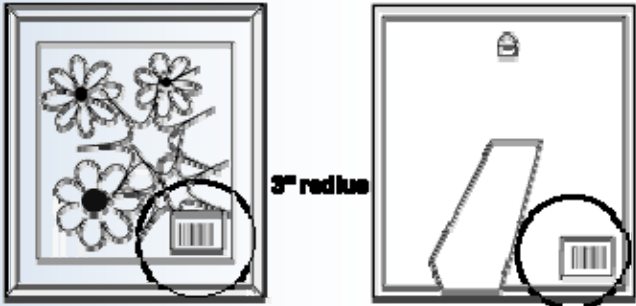

8.3.2.3 Removed at Point-of-Sale Anti-Theft Tags

This section addresses placement guidelines for removed at point-of-sale anti-theft tags. These tags are generally applied by the retailer and removed by the retailer at point-of-sale. They include the following tag types:

- ◆ Hard tags - EAS device encased in plastic housing with tack or clamp application.
- ◆ Benefit denial - Anti-theft devices with vials of permanent ink that if defeated render the merchandise worthless, or locking devices that must be removed at point-of-sale.
- ◆ Disposable hard tags - applied with a tack, that may be removed by the retailer at point-of-sale or by the consumer.

Generally, placement of "removed at point-of-sale" anti-theft tags in apparel is in the left side seam, **6" to 10"** above the garment bottom or hemline. In fashion accessories (jewelry, watches, handbags, small leather goods, belts/suspenders, millinery, scarves/shawls, gloves/mittens, eyewear, ties/neckwear), "removed at point-of-sale" anti-theft tags are attached with a tack, clamp, lanyard, or magnet through a strap, band, or sewn in label.

Accessories

Backpacks



Belts

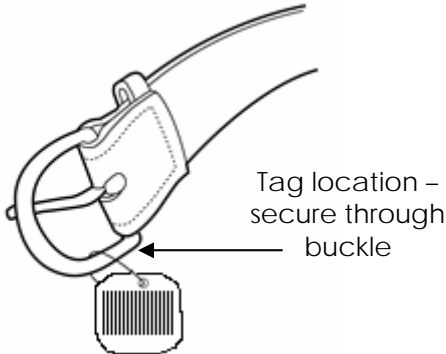

Cummerbunds



Eyewear

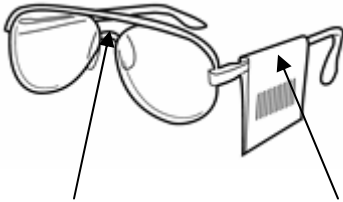

Suspenders



Key Chains

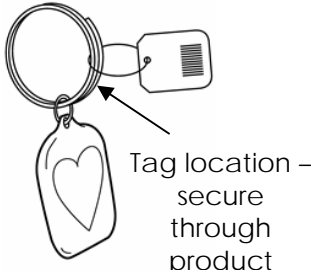

Accessories

Scarves/Shawls

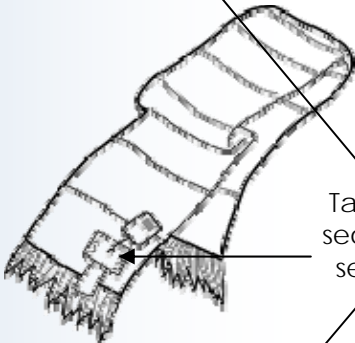

Tag location – secure through sewn-in label

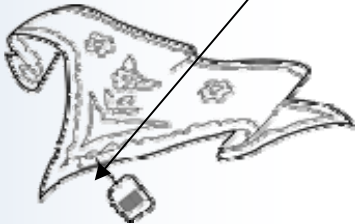

Loose Jewelry



Tag location – secure through product

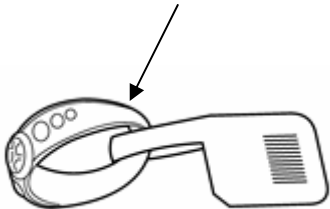

Gloves/Mittens

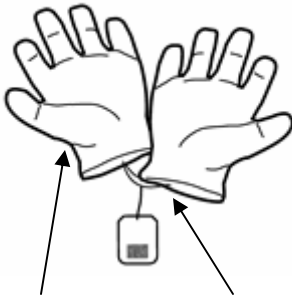

Tag location – secure through side seam or sewn-in label

Dickies

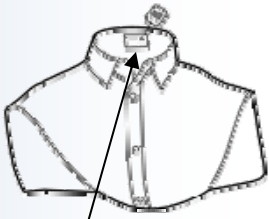

Tag location – secure through label/collar seam

Accessories

Hats

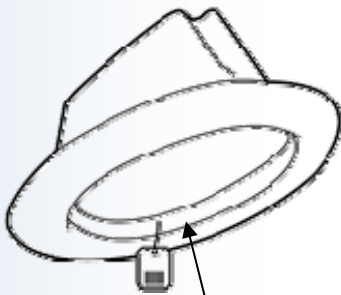

Tag location – secure through headband

Hats, knit



Tag location – secure through seam or sewn in label

Handbags, purses

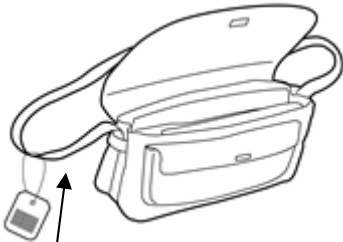

Tag location – secure through strap

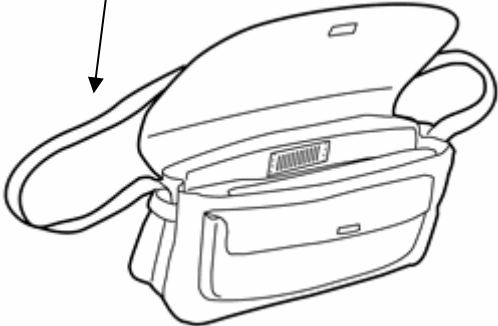

Apparel - Bottoms

Overalls/Shortalls/Rompers

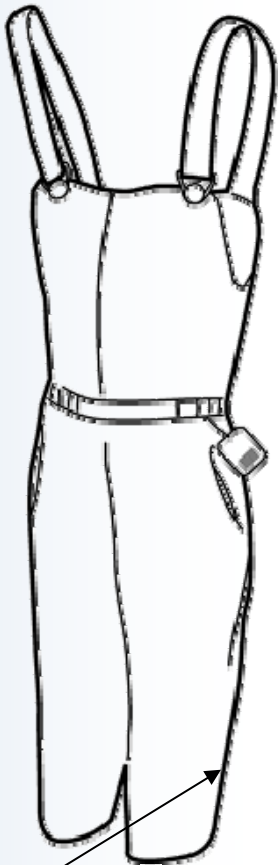

Tag location - left seam, 6 - 8" from bottom/hemline

Pants/Slacks/Jeans, Hanging



Tag location - left seam, 6-10" from bottom/hemline

Pants/Slacks/Jeans, Folded

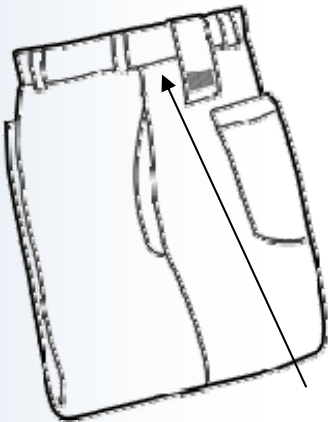

Tag location - waist seam, left back or 6-8" from bottom



Apparel - Bottoms

Shorts/Trunks

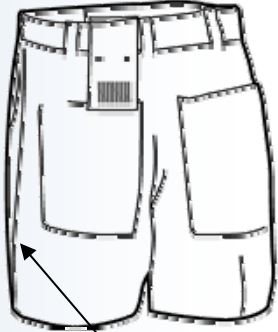

Tag location - left seam, 6-8" from bottom/hemline

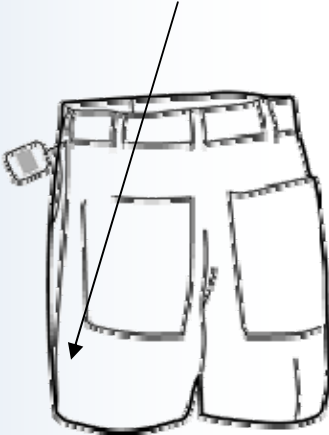

Skirts

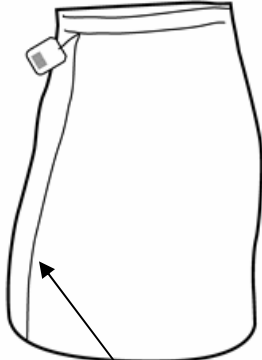

Tag location - left seam, 6 - 8" from bottom/hemline

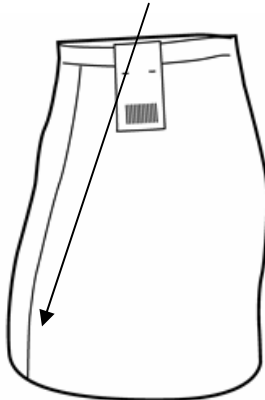

Clothing/Outerwear

Sport Coats/Blazers/Suits

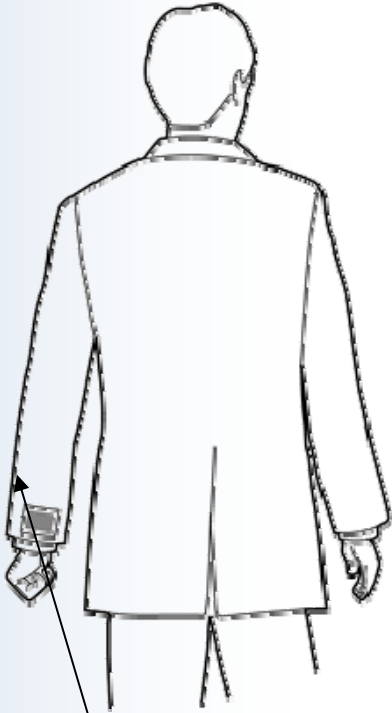

Tag location – left seam, 6-8” from bottom/hemline

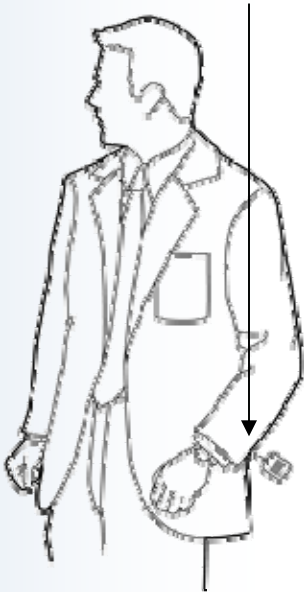

Outerwear (Coats, Jackets)



Tag location – left seam, 6-10” from bottom/hemline



Outerwear (Parkas, Ponchos)



Tag location – collar/label seam

Clothing/Outerwear

Vests

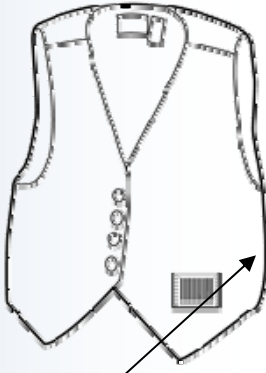

Tag location – left seam, 6-8" from bottom/hemline

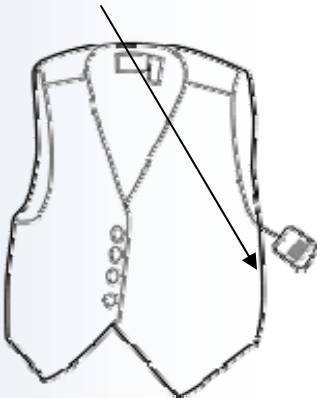

Women's and Girl's Blazers/Suits



Tag location – left seam, 6-8" from bottom/hemline



Clothing/Outerwear

Dresses, With Sleeves



Tag location – left seam, 6-10" from bottom/hemline



Dresses, Sleeveless



tag location – left seam, 6-10" from bottom/hemline



Tops

Tops, Folded

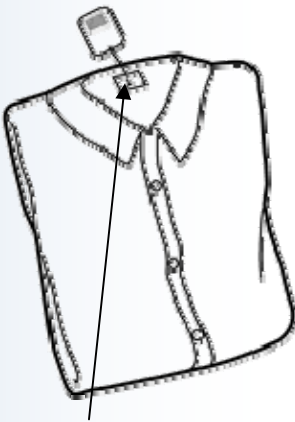

Tag location - collar/label seam

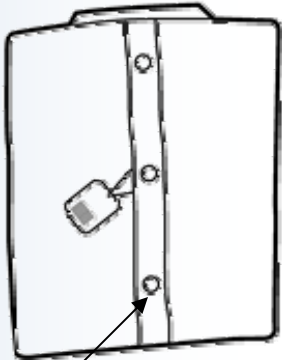
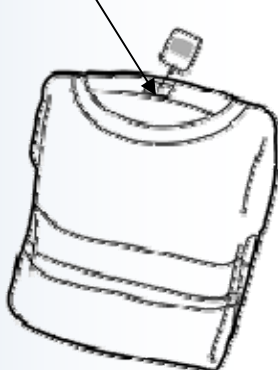

Tag location - first buttonhole on backside of fold

Tops, Hanging Long Sleeve



Tag location - left seam, 6-8" from bottom/hemline



Tops

Tops, Hanging Short Sleeve



Tag location – left seam, 6-8" from bottom/hemline

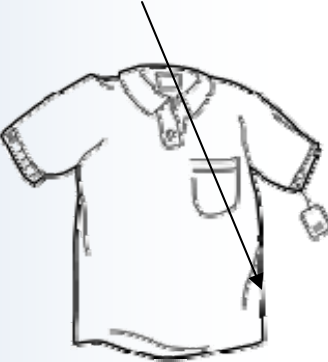

Tops, Hanging Sleeveless



Tag location – left seam, 6-8" from bottom/hemline



Intimate Apparel/Underwear

Bras

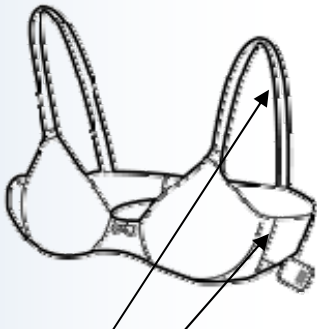

Tag location – secure through left strap or left seam

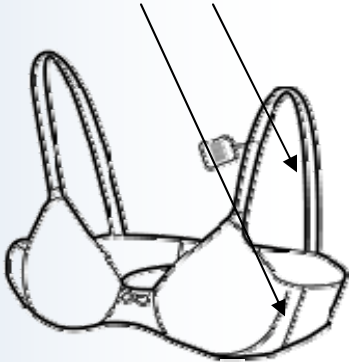

Camisoles/Teddies

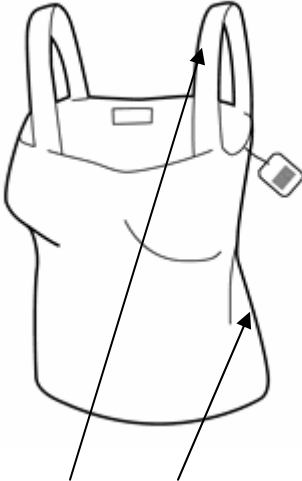

Tag location – secure through left strap or left seam, 6-8" from bottom



Panties/Control Garments

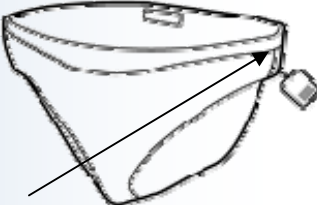

Tag location – left seam or back or front if no side seam

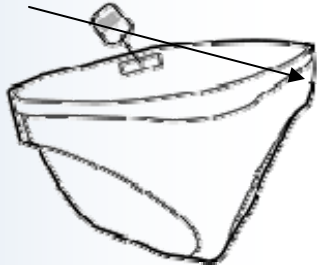

Intimate Apparel/Underwear

Sleepwear/Robes

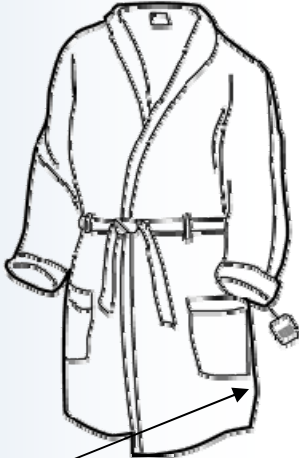

Tag location – left seam, 6-10" from bottom/hemline

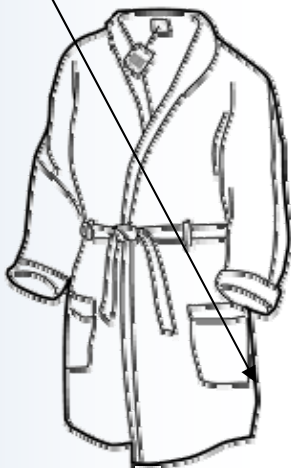

Slips



Tag location – left seam, 6-10" from bottom/hemline



Boxer Shorts

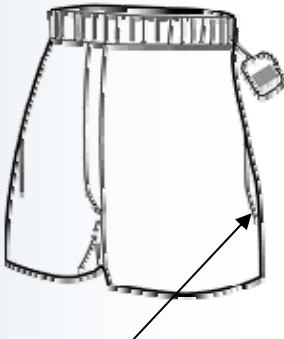

Tag location – left seam, 6-8" from bottom/hemline

Intimate Apparel/Underwear

Swimwear/Bodywear/Dancewear, One-Piece

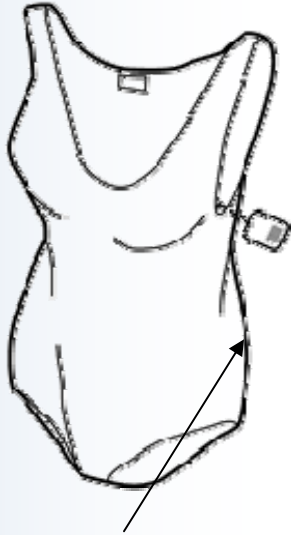

Tag location – left seam, 6-8" from bottom

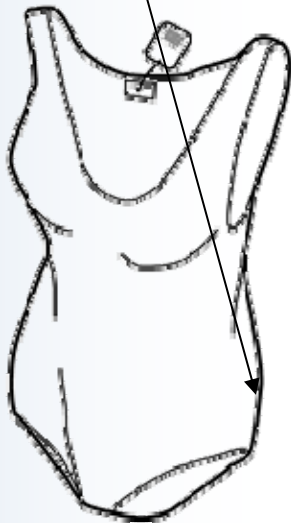

Swimwear/Bodywear/Dancewear, Two-Piece

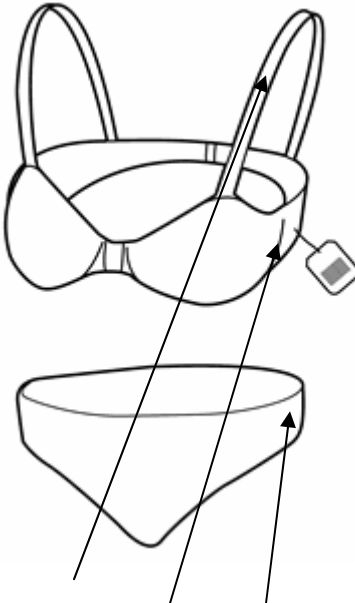

Tag location – one or two tags; top left seam or through strap; bottom left seam or back or front if no seam

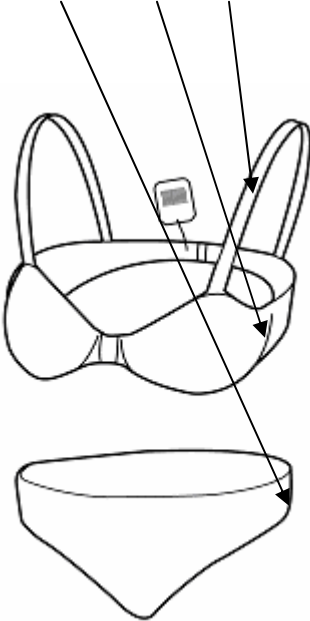

8.4 Training Considerations

Training is necessary to ensure effective use of anti-theft tags. The technology provider, retailer, or manufacturer may provide training dependent on the topic and who can best provide the training. For example, training for tag application may be provided by the technology provider at the retailer, if the tags are applied at that point, or at the product manufacturer, if the tags are applied during manufacturing or distribution. The chart below lists some of the possible components of anti-theft tag training and the possible training provider(s).

Training Component	Training Provider		
	Technology Provider	Retailer	Product Manufacturer
EAS system operation, monitoring, and maintenance	X	X	X
Which products will be tagged		X	X
Tag application including how to apply and proper placement	X	X	X
Tag activation, deactivation, and removal as applicable	X	X	X
Tag disposal, recycling, and reuse requirements as applicable	X	X	
Tagging compliance auditing requirements		X	X
Procedures for handling alarms at retail	X	X	

8.5 Trading Partner Discussion Checklist

Anti-theft tag placement is product-specific. The discussion points in the checklist may be used as a guideline for the development of a checklist that is appropriate to the product category under discussion. This list is not intended to be inclusive or exhaustive; it will serve as a starting point for the development of your own set of discussion points.

- ◆ Technology choice
- ◆ Which products to tag
- ◆ Type of anti-theft tags to use by product and the appropriate placement
- ◆ Where the tags should be applied: By the retailer at the retail or distribution level or by the source before receipt by the retailer
- ◆ Policies and procedures for:
 - ◆ System monitoring and maintenance
 - ◆ Tagging compliance audits at retail or source as applicable
 - ◆ Tag disposal, recycle or reuse requirements as applicable
 - ◆ Handling alarms at retail
- ◆ Training requirements and who will provide